

KITCHEN COMPACT

Cabinets



DWhite

BY KITCHEN KOMPACT



Our recessed panel, Shaker style cabinets are available in painted white. This painted wood door style enables a variety of design options with countertops, flooring and decorative backsplashes. Door pulls not included.

Please refer to the List Price and Specification Booklet (page 11) for Wood Characteristics and Painted Finishes. For more information, see the warranty section at kitchencompact.com/warranty.

Watch the DWhite touch-up kit video at kitchencompact.com/dwkit.



Loyalty @kitchencompact

Our employees average 15 years of service!



kitchencompact.com



GLENWOOD



For those who want a darker, chocolate color and up-to-date Shaker style, choose our best selling line, **Glenwood**. The clean, well-defined edges and **recessed panel** doors bring a touch of elegance to your home. Door pulls not included.



Location @kitchencompact

We are located in Jeffersonville, Indiana, across the Ohio River from Louisville, Kentucky.



kitchencompact.com



WARMWOOD



Not as dark as Glenwood, **Warmwood's** chestnut brownish tone, clean lines, and **recessed panel** doors give you another choice in our most popular Shaker style. Door pulls not included.



American-Made @kitchencompact

Our cabinets are proudly made in the USA!



kitchencompact.com



CHADWOOD



A traditional classic with a golden oak finish, **Chadwood** is right at home in any kitchen. With its *oak recessed panel* doors, **Chadwood** can be designed and accessorized to fit any need, taste or budget. Door pulls not included.



Family @kitchencompact

Founded by Dwight Gahm, we are now joined by a third generation!



kitchencompact.com

Wall Cabinets

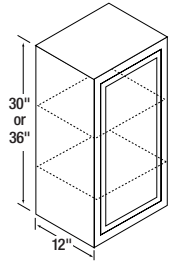

36" High Wall Cabinets (WT)

Item	Glenwood	Warmwood	Chadwood	DWhite
9WT*	192	192	211	217
12WT*	207	207	226	232
15WT*	218	218	246	247
18WT*	236	236	268	262
21WT*	256	256	293	276
24WT*	272	272	313	292
27WT	331	331	384	398
30WT	348	348	401	412
33WT	365	365	423	426
36WT	387	387	445	445

*Single door. Single door wall units are reversible for right or left hinging, simply turn the cabinet over.

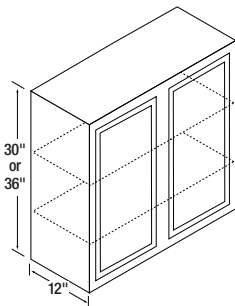

30" High Wall Cabinets (W)

Item	Glenwood	Warmwood	Chadwood	DWhite
9W*	161	161	174	196
12W*	176	176	192	209
15W*	194	194	211	225
18W*	208	208	229	237
21W*	225	225	249	251
24W*	240	240	266	264
27W	315	315	327	365
30W	328	328	340	378
33W	348	348	361	393
36W	364	364	378	406
42W	403	403	418	433
48W	441	441	464	463

*Single door. Single door wall units are reversible for right or left hinging, simply turn the cabinet over.

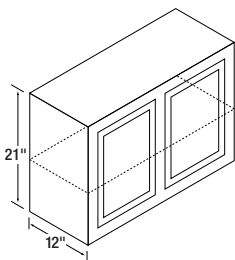

21" High Wall Cabinets (R)

Item	Glenwood	Warmwood	Chadwood	DWhite
24R*	194	194	213	223
30R	248	248	267	319
36R	273	273	295	342

*Single door.

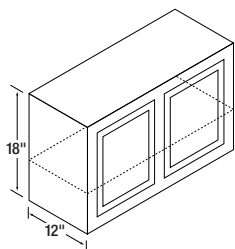

18" High Wall Cabinets (Y)

Item	Glenwood	Warmwood	Chadwood	DWhite
24Y*	180	180	196	211
30Y	230	230	245	303
36Y	256	256	274	327

*Single door.

Please refer to page 12 for Wood Characteristics & Finishes.

For more information, see the warranty section at kitchencompact.com/warranty.

Watch the DWhite touch-up kit video at kitchencompact.com/dwkit.

Wall Cabinets *cont'd*

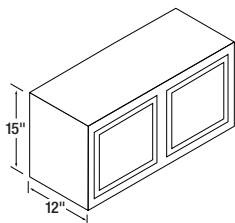

15" High Wall Cabinets (X)

Item	Glenwood	Warmwood	Chadwood	DWhite
30X	199	199	210	273
33X	209	209	222	282
36X	219	219	232	292

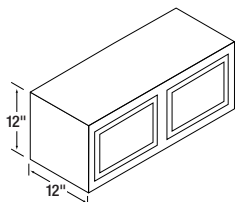

12" High Wall Cabinets (X12)

Item	Glenwood	Warmwood	Chadwood	DWhite
30X12	183	183	193	257
36X12	200	200	209	274

Wall Corner Cabinets

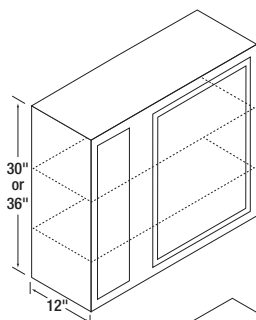

36" High Wall Corner Cabinets (WCT)

Item	Glenwood	Warmwood	Chadwood	DWhite
24WCT*	270	270	305	305
36WCT*	348	348	394	370

All lines may be pulled 4-1/2".
*Single door.

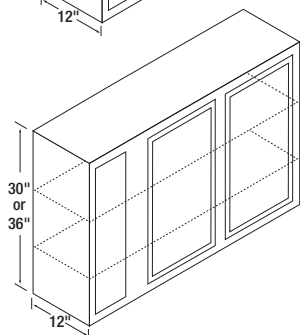

30" High Wall Corner Cabinets (WC)

Item	Glenwood	Warmwood	Chadwood	DWhite
24WC*	239	239	261	275
36WC*	304	304	337	330
42WC	372	372	411	442

All lines may be pulled 4-1/2".
*Single door.

24WC Can pull to 28-1/2" - One 6" opening. One 6" Stile. One 9" opening for a 27 x 9-1/2" door.

36WC Can pull to 40-1/2" - One 6" opening. One 6" Stile. One 21" opening for a 27 x 21-1/2" door.

42WC Can pull to 46-1/2" - One 6" opening. One 6" Stile. Two 12" openings for two 27 x 12-1/2" doors. One 3" Stile (between 12" openings).

Angle Wall Cabinets

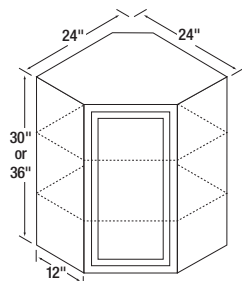

36" High Angle Wall Cabinet (AT)

Item	Glenwood	Warmwood	Chadwood	DWhite
24AT	361	361	403	394

30" High Angle Wall Cabinet (A)

Item	Glenwood	Warmwood	Chadwood	DWhite
24A	327	327	357	361

Base Cabinets

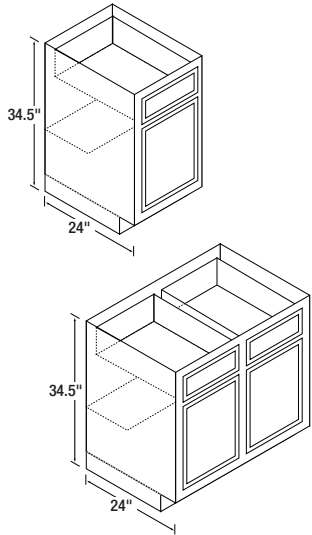

Base Cabinets (B)

Item	Glenwood	Warmwood	Chadwood	DWhite
12B*	289	289	310	328
15B*	311	311	334	348
18B*	332	332	360	368
21B*	354	354	385	388
24B*	377	377	413	410
27B* (3" Side Stiles)	406	406	446	438
30B	493	493	533	571
33B (3" Side Stiles)	513	513	558	592
36B	533	533	579	608
42B	584	584	640	658
48B	629	629	695	699

Toe Kick is 4" high x 3" deep.

*Single door. Single door base units are reversible, simply hang door right or left, using holes predrilled in rails.

Tray Cabinet

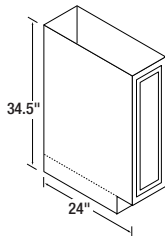

Tray Cabinet (T)

Item	Glenwood	Warmwood	Chadwood	DWhite
9T	215	215	234	252

Drawer Cabinets

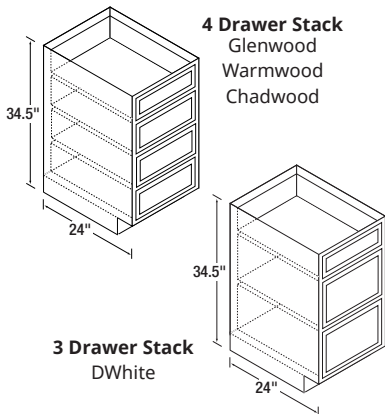

Drawer Cabinets (D)

Item	Glenwood	Warmwood	Chadwood	DWhite
15D	516	516	555	502
18D	558	558	607	540
24D	641	641	702	618

Available only as
4 drawer stack

Available only as
4 drawer stack

Available only as
4 drawer stack

Available only as
3 drawer stack

Base Corner Cabinets

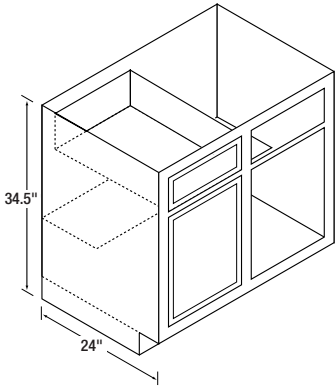

Base Corner Cabinets (BC)

Item	Glenwood	Warmwood	Chadwood	DWhite
39BC	422	422	455	464
42BC	462	462	502	503

39BC must be pulled to 39" and may be pulled to 46". 42BC may be pulled to 49".

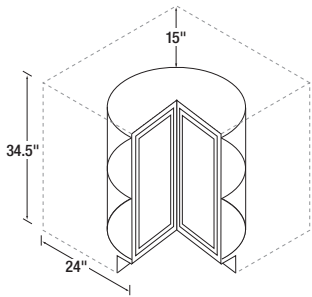
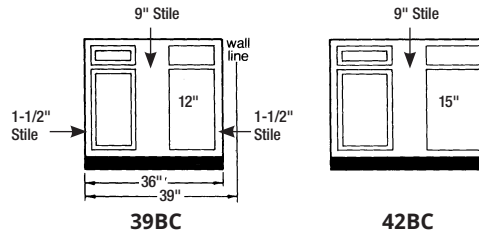

Lazy Susan Corner Cabinet (LS)

Item	Glenwood	Warmwood	Chadwood	DWhite
36LS	566	566	620	544

Lazy Susan is 34-1/2" high and takes up 36" on each wall. Actual shelf is 24" diameter. Shipped without end panels.

Peninsula Base Cabinets

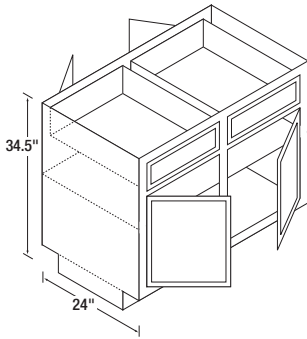

Peninsula Base Cabinets (P)

Item	Glenwood	Warmwood	Chadwood	DWhite
36B-P	702	702	791	772
48B-P	838	838	967	895
48BC-P	756	756	868	821

BC-P indicates Blind Corner Peninsula.

Range & Sink Base Cabinets

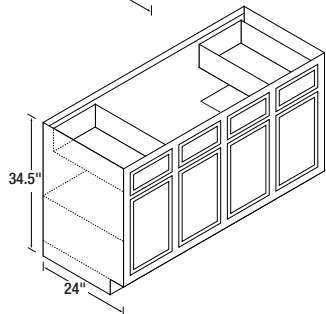
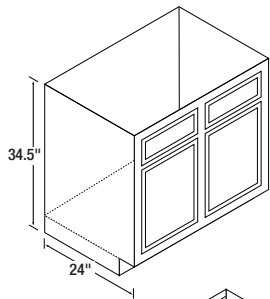

Range & Sink Base Cabinets (RBS)

Item	Glenwood	Warmwood	Chadwood	DWhite
30RBS	369	369	404	465
33RBS (3" Side Stiles)	388	388	429	485
36RBS	396	396	438	489
42RBS	436	436	487	526

Sink Base Cabinets (SB)

Item	Glenwood	Warmwood	Chadwood	DWhite
60SB	751	751	822	855

No shelf under sink (center section) and no back on cabinet.
Combination unit consists of 15-30-15.
Opening between drawers on **60SB** is 33".

Sink Front

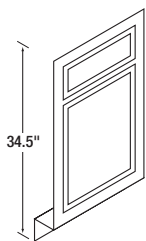

Sink Front (SF)

Item	Glenwood	Warmwood	Chadwood	DWhite
18SF*	141	141	163	169

*Square edge.

Oven Cabinets

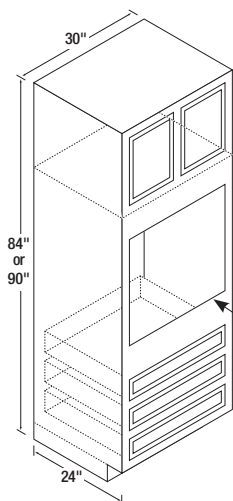

90" High Oven Cabinet (OUT)

Item	Glenwood	Warmwood	Chadwood	DWhite
30OUT	1,154	1,154	1,285	1,243

Metal support rails included.

84" High Oven Cabinet (OU)

Item	Glenwood	Warmwood	Chadwood	DWhite
30OU	1,087	1,087	1,217	1,192

Metal support rails included.

To accommodate almost every type of oven, the opening can be cut from a minimum width of 21" to a maximum width of 28.5" and a minimum height of 27.5" to a maximum height of 60" (One or more lower drawers may need to be removed).

Broom Cabinets

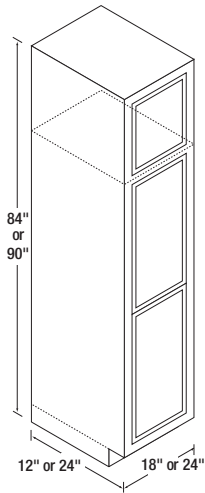

90" High Broom Cabinets (BRT)

Item	Glenwood	Warmwood	Chadwood	DWhite
18BRWT (12" deep)	557	557	619	621
18BRBT (24" deep)	748	748	817	818
24BRBT (24" deep)	899	899	986	876

84" High Broom Cabinets (BR)

Item	Glenwood	Warmwood	Chadwood	DWhite
18BRW (12" deep)	521	521	576	585
18BRB (24" deep)	701	701	763	772
24BRB (24" deep)	769	769	847	827

No shelves included with **Broom Cabinets**. Optional **Shelf Kit** Includes four (4) shelves and clips: **18BRW/BRWT** kits @ \$68/kit, **18BRB/18BRBT** kits @ \$124/kit, and **24BRB/BRBT** kits @ \$165/kit.

Accessories

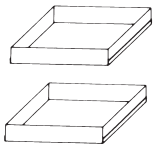

Accessories Pantry/Base Roll-Out Tray (priced per box - packaged 2 trays per box)

Item	Glenwood	Warmwood	Chadwood	DWhite
15BT	201	201	201	201
18BT	217	217	217	217
24BT	229	229	229	229

Vanity Cabinets

30.5" High Vanity Cabinets (V)

Item	Glenwood	Warmwood	Chadwood	DWhite
V12B	253	253	271	292
V15D	434	434	451	459
V24S	282	282	308	296
V30S	330	330	359	404
V36S	360	360	394	432
V36SD	502	502	552	527
V42S*	521	521	567	604
V48S*	561	561	612	641

Opening between drawers on **V42S/V48S** is 21.5".
*Two outside working drawers.

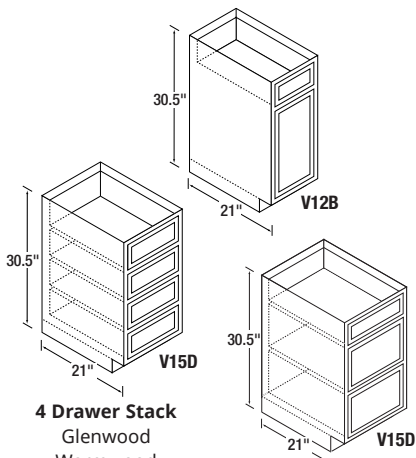

4 Drawer Stack
Glenwood
Warmwood
Chadwood

3 Drawer Stack
DWhite

4 Drawer Stack
Glenwood
Warmwood
Chadwood

3 Drawer Stack
DWhite

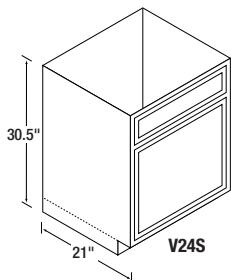

V24S

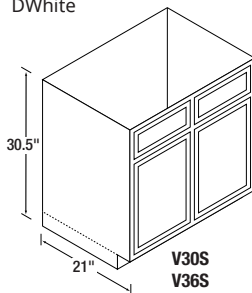

V30S
V36S

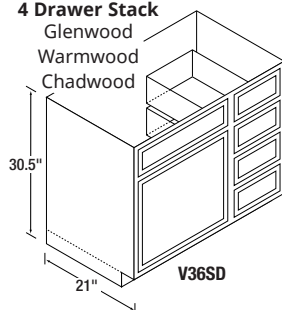

V36SD

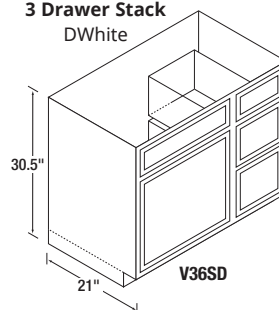

V36SD

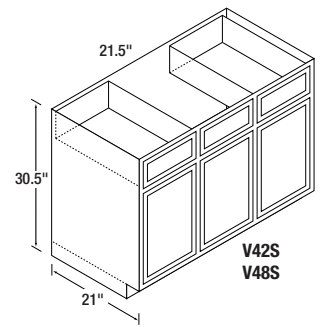

V42S
V48S

Vanity Cabinets *cont'd*

34.5" High Vanity Cabinets (VT)

Item	Glenwood	Warmwood	Chadwood	DWhite
V12BT	274	274	NA	312
V15DT	512	512	NA	492
V24ST	304	304	NA	320
V30ST	359	359	NA	432
V36ST	390	390	NA	460
V36SDT	578	578	NA	550
V42ST*	565	565	NA	645
V48ST*	606	606	NA	684

Opening between drawers on **V42S/V48S** is 21.5".

*Two outside working drawers.

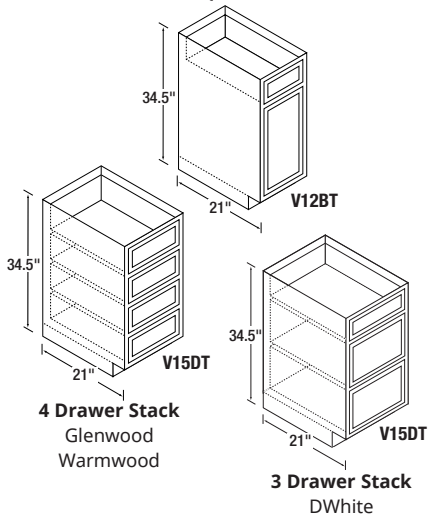

4 Drawer Stack
Glenwood
Warmwood

3 Drawer Stack
DWhite

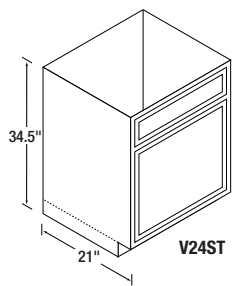

V24ST

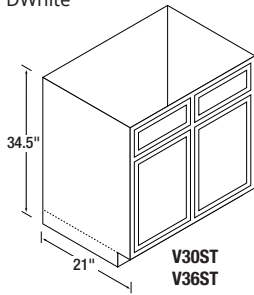

V30ST
V36ST

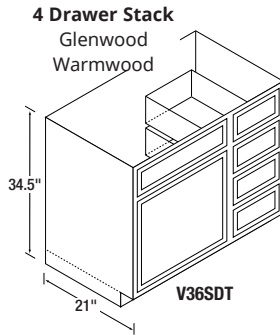

V36SDT

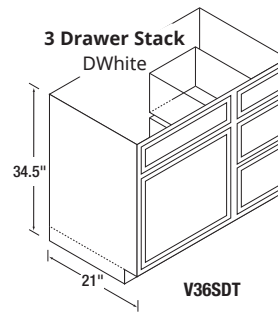

V36SDT

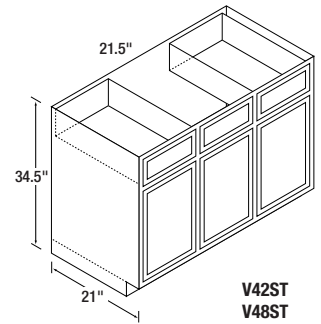

V42ST
V48ST

All Standard/Tall Vanities 21" Deep.

Miscellaneous Items

Miscellaneous Items

Item	Glenwood	Warmwood	Chadwood	DWhite
Valance Boards				
48" Val 3/4" x 5-1/2" x 48" (6 to box) Per piece	62	62	90	72
72" Val 3/4" x 5-1/2" x 72" (6 to box) Per piece	82	82	121	94
Filler Strips				
3" Filler Strips 3"W x 36"L (12 to box) Per piece	31	31	39	36
6" Filler Strips 6"W x 36"L (6 to box) Per piece	47	47	80	56
3" Filler Strips 3"W x 90"L (12 to box) Per piece	67	67	95	77
Touch-Up				
Touch-Up Pens (12 to box) Per pen	39	39	41	NA
Pints of Stain Per pint	69	69	47	NA
Touch-up Kits Per kit	NA	NA	NA	133

Learn more about the DWhite touch-up kit at kitchencompact.com/dwkit.

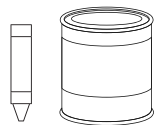
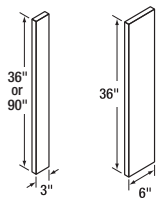
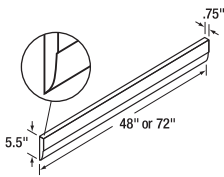

Miscellaneous Items *cont'd*

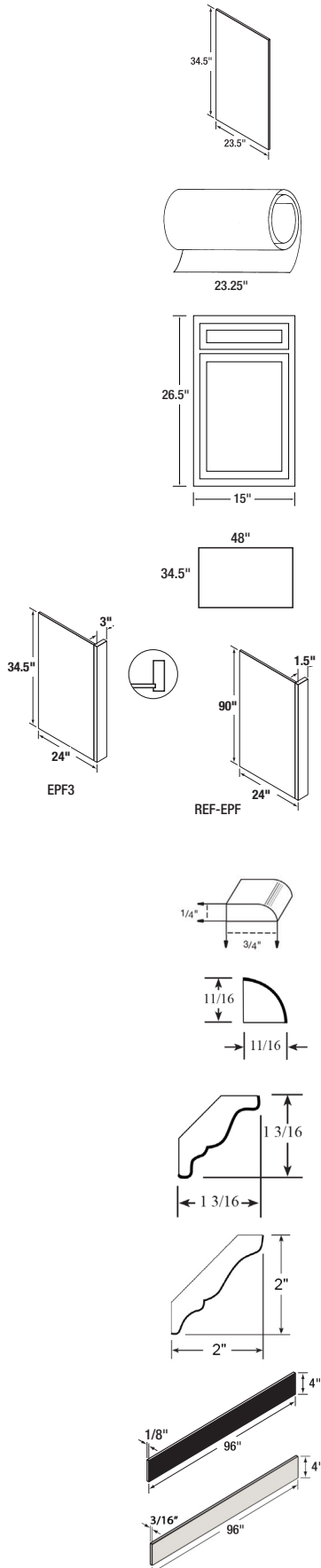

Item	Glenwood	Warmwood	Chadwood	DWhite
Base End Panels - EP May be used R or L 1/2" x 23-1/2" x 34-1/2" (6 to box) Per piece	67	67	69	77
END COVERS (self-adhesive backing) Base End Cover - 23-1/4" x 34-1/2" (6 to box) Per piece	154	154	146	NA
Oven End Cover - 23-1/4" x 90" (6 to box) Per piece	420	420	395	NA
Salesman Sample Door & Frame 15" x 26-1/2" Front (4 to box) Per piece	165	165	182	195
Back Panels (also for dishwashers) 3/16" x 34-1/2" x 48" (6 to box) Per piece	177	177	165	205
End Panel Faced - EPF3 Faced with 3" stile. 1/2" x 24" x 34-1/2" (4 to box) Per piece	119	119	131	138
REF - EPF (Refrigerator End Panel) Faced with 1.5" stile. 1/2" x 24" x 90" (2 to box) Per piece	268	268	294	455
Scribe Molding 1/4" x 3/4" x 96" (63 pieces/504' to box) Per piece	47	47	35	46
Quarter Round Molding 11/16" x 11/16" x 96" (25 pieces/200' to box) Per piece	43	43	39	39
CROWN MOLDING Small Crown Molding 1-3/16" x 1-3/16" x 96" (15 pieces/120' to box) Per piece	75	75	69	68
Large Crown Molding 2" x 2" x 96" (16 pieces/128' to box) Per piece	120	120	124	109
Toe Kick Material Black Hardboard 1/8" x 4" x 96" (25 pieces/200' to box) Per piece	19	19	19	19
Matching Toe Kick Material Finished TK 3/16" x 4" x 96" (25 pieces/200' to box) Per piece	67	67	64	63

ADA Accessible Cabinets

Kitchen Kompact offers 32-1/2" high base cabinets to help comply with ADA (Americans with Disabilities Act) requirements. Such cabinets are especially important for multi-family projects subject to HUD and FHA funding. Kitchen Kompact will only provide ADA accessible cabinets on multi-family projects where the ADA accessible units are 10% or less of the entire project. These cabinets are special order and are available in all door styles. Please allow a minimum of two weeks for delivery.

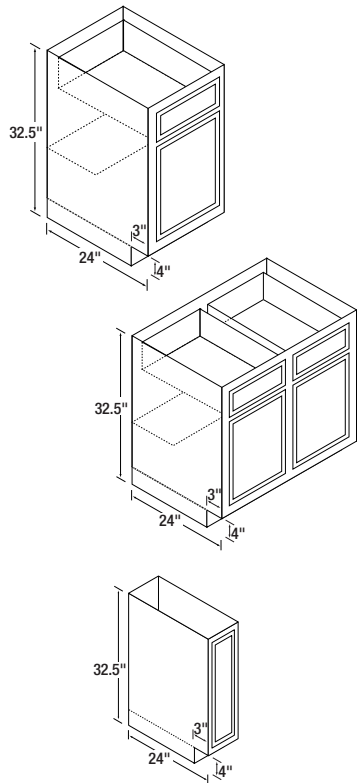

Universal Design Base Cabinets

Item	Glenwood	Warmwood	Chadwood	DWhite
UD12B*	347	347	372	393
UD15B*	373	373	401	418
UD18B*	399	399	432	441
UD21B*	425	425	462	466
UD24B*	452	452	495	492
UD27B* (3" Side Stiles)	487	487	535	526
UD30B	591	591	639	686
UD33B (3" Side Stiles)	615	615	670	710
UD36B	639	639	695	730
UD42B	701	701	768	789
UD48B	754	754	834	838

Toe Kick is 4" high x 3" deep.

*Single door. Single door base units are reversible, simply hang door right or left, using holes predrilled in rails.

Universal Design Tray Cabinets

Item	Glenwood	Warmwood	Chadwood	DWhite
UD9T	257	257	281	302

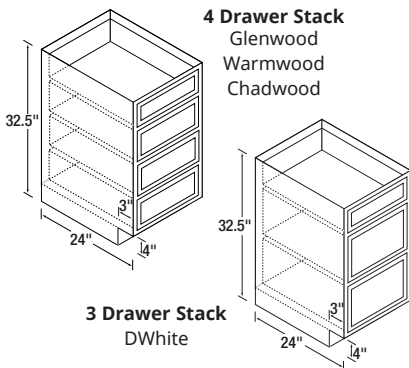

Universal Design Drawer Cabinets

Item	Glenwood	Warmwood	Chadwood	DWhite
UD15D	620	620	666	603
UD18D	669	669	728	648
UD24D	770	770	842	742
	Available only as 4 drawer stack	Available only as 4 drawer stack	Available only as 4 drawer stack	Available only as 3 drawer stack

Universal Design Range & Sink Base Cabinets

Item	Glenwood	Warmwood	Chadwood	DWhite
UD30RBS	443	443	485	558
UD33RBS (3" Side Stiles)	466	466	515	582
UD36RBS	476	476	525	587
UD42RBS	524	524	584	631

Universal Design Base Corner Cabinets

Item	Glenwood	Warmwood	Chadwood	DWhite
UD39BC	507	507	546	556
UD42BC	555	555	602	603

UD39BC must be pulled to 39" and may be pulled to 46". UD42BC may be pulled to 49".

ADA Accessible Cabinets *cont'd*

Handicapped Design Base Cabinets

Item	Glenwood	Warmwood	Chadwood	DWhite
H12B*	347	347	372	393
H15B*	373	373	401	418
H18B*	399	399	432	441
H21B*	425	425	462	466
H24B*	452	452	495	492
H27B* (3" Side Stiles)	487	487	535	526
H30B	591	591	639	686
H33B (3" Side Stiles)	615	615	670	710
H36B	639	639	695	730
H42B	701	701	768	789
H48B	754	754	834	838

Toe Kick is 8.75" high x 6" deep.

*Single door. Single door base units are reversible, simply hang door right or left, using holes predrilled in rails.

Handicapped Design Drawer Cabinets

Item	Glenwood	Warmwood	Chadwood	DWhite
H15D	620	620	666	603
H18D	669	669	728	648
H24D	770	770	842	742

Available only as
3 drawer stack

Available only as
3 drawer stack

Available only as
3 drawer stack

Available only as
2 drawer stack

Handicapped Design Base Corner Cabinets

Item	Glenwood	Warmwood	Chadwood	DWhite
H39BC	507	507	546	556
H42BC	555	555	602	603

H39BC must be pulled to 39" and may be pulled to 46". H42BC may be pulled to 49".

Handicapped Design Range & Sink Base Cabinet

Item	Glenwood	Warmwood	Chadwood	DWhite
H30RBS	443	443	485	558
H33RBS	466	466	515	582
H36RBS	476	476	525	587
H42RBS	524	524	584	631

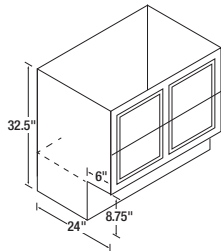
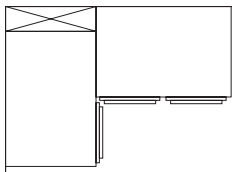
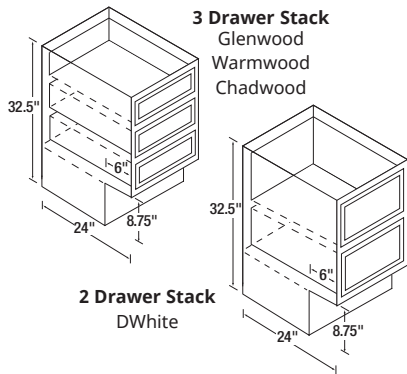
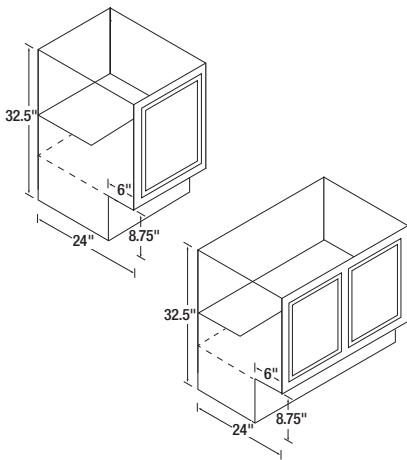

Door Styles

Glenwood and Warmwood: Shaker style door frames are made of solid beech, mortised and tenoned. The recessed plywood insert is three-ply with a rotary cut hard maple veneer. Drawer heads have routed finger pulls.



Glenwood

Warmwood

Chadwood: Solid Appalachian oak frames are joined by mortise and tenon. The recessed plywood insert is three-ply with a rotary cut red oak veneer. Drawer heads have routed finger pulls.

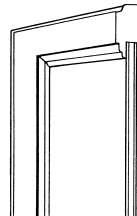

Chadwood Oak

DWhite: Painted white shaker style door frames are made of solid beech and/or poplar, mortised and tenoned. The recessed MDF or plywood insert is a three-ply with a rotary cut hard maple veneer. Drawer heads have routed finger pulls.

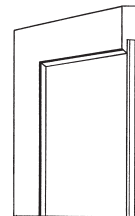

DWhite

Mouldings to Match Kitchen Kompact

Effective: June 13, 2022

Profile	Code	Description	Glenwood/ Warmwood	Chadwood	White
	SM	Scribe Mold 96"	\$47.00	\$35.00	\$46.00
	BM	Batten Mold 96"	\$45.00	\$36.00	\$38.00
	QRM	Quarter Round Mold 96"	\$43.00	\$39.00	\$39.00
	OCS	Outside Corner 96"	\$56.00	\$63.00	\$66.00
	IC	Inside Corner 96"	\$56.00	\$63.00	\$66.00
	CRM	Crown (Large) 96"	\$120.00	\$124.00	\$109.00
	CSM	Crown (Small) 96"	\$75.00	\$69.00	\$68.00
	TKC	Toe Kick 96"	\$67.00	\$64.00	\$63.00
	PVB	48x96 Panel	\$464.00	\$472.00	\$464.00
	PVCG	96x48 Cross Grain Panel	\$630.00	\$610.00	-

Specifications

Cabinet Construction

All face frames are 3/4" kiln-dried rails, joined by mortise and tenon with glue. Glenwood and Warmwood, are built using a mixture of solid beech and sycamore. DWhite face frames are built using a mixture of solid beech, sycamore and poplar. Chadwood face frames are built using solid oak. All wall and base cabinets have 1/8" backs. Wall cabinets are equipped with solid wood hanging rails at back, both top and bottom. End panels are wood veneered, 1/2" thick engineered wood core plywood, fastened to front frame with tongue-in-groove construction. Tops and bottoms are 3/16" hardboard dadoed into sides, interlocked into hanging rails of all wall units, and secured with an adhesive for added strength.

Finish

A 4-step process is applied to the exterior finish of Glenwood, Warmwood, and Chadwood: Stain, Sealer, Sanding, and Catalyzed Top Coat.

A 3-step process is applied to the exterior finish of DWhite: Primer, Sanding, and Enamel.

Wood Characteristics & Finishes

On all wood products, expansion, contraction, and warping are typical due to changes in climate conditions. Painted finishes may develop slight separation lines, finish breaks, and seam lines. These changes will be most noticeable at the stiles, rails, and panel joints. Painted and stained finishes are also susceptible to changes in color due to exposure to natural light, extreme heat, smoke, etc. The changes may become more noticeable over time and through seasonal changes. These changes are normal and are not considered quality defects.

Shelves

All wall cabinets feature adjustable shelves. A selection of six different heights is built into each 30" high and taller wall cabinet. On 2-door wall units, the center 3" stile is used for center support of adjustable shelves. It is recommended that a 1/4" hole be drilled in the back for additional center support. The extra shelf clip is provided. Shelves are 1/2" engineered wood, with rounded front edge and printed wood grain.

Hardware

Chadwood, Glenwood, Warmwood, and DWhite feature concealed self-closing hinges - no door pulls included.

Vanities

Vanity size cabinets are available in all lines. Tall vanities only available in Glenwood, Warmwood, and DWhite.

Doors

Chadwood: Door frames are mortised and tenoned construction of solid oak. The recessed plywood insert is three-ply with a rotary cut red oak veneer.

Glenwood/Warmwood: Shaker style door frames are made of solid beech, mortised and tenoned. The recessed plywood insert is three-ply with a rotary cut hard maple veneer.

DWhite: Painted white shaker style door frames are made of solid beech and/or poplar, mortised and tenoned. The recessed MDF or plywood insert is a three-ply with a rotary cut hard maple veneer.

Drawers

Drawers operate with a full front to back epoxy coated suspension system on nylon rollers.

Drawer fronts of solid oak, poplar, and beech are finger routed on the bottom for easy opening.

Oven Cabinets

Oven cabinets are made to accommodate almost every type oven by removing the necessary lower drawer units. Metal support rails are included.

ADA Accessible Cabinets

Kitchen Kompact will only provide ADA accessible cabinets on multi-family projects where the ADA accessible units are 10% or less of the entire project. ADA accessible cabinets are available, on special order, in a limited number of sizes.

Outline Specifications

Kitchen cabinets shall be as manufactured by Kitchen Kompact according to the company's material specifications. Finishes and cabinet units (Chadwood, Glenwood, Warmwood, and DWhite) are as specified by size and type according to Kitchen Kompact stock catalogs. Cabinets are reversible so there is no need to specify left or right. Hardware, finish, materials, and other requirements shall be as specified by Kitchen Kompact. Each cabinet is shipped individually and in its own carton.

Cabinet Code Descriptions

For ease of ordering, the numerical designation indicates the cabinet width, the letter identifies the height.

Flexible Installation

Wall cabinets are reversible for right- or left-hand installation. Base cabinets come hinged left, but can be easily reversed by moving hinges to predrilled right-hand locations.

General Information

Orders are taken subject to our approval. Any changes must be made within four days after date of our acknowledgment. If this notice is not received, cabinets will be shipped according to the acknowledgment. Orders are not subject to cancellation without our written consent. Do not return merchandise to factory without our permission. All merchandise shipped in good condition - any damage claims must be made with delivering carrier.

For Installation and Care Guidelines, visit our website!
kitchenkompact.com

SUBJECT TO CHANGE WITHOUT NOTICE. SHIPMENTS F.O.B. JEFFERSONVILLE. Kitchen Kompact cabinets meet or exceed the American National Standards Institute #A161.1 recommended minimum construction and performance standards for kitchen and vanity cabinets.

Kitchen Kompact, Inc. reserves the right to change design, specifications, or materials without being obliged to incorporate such changes in products of prior manufacture. The artwork and specifications contained herein are the property of Kitchen Kompact, Inc., and may not be copied or reproduced without the written consent of the company.



Kitchen Kompact, Inc.
911 East 11th St. (47130)
P.O. Box 868
Jeffersonville, IN 47131-0868
(812) 282-6681 Phone
(812) 282-7880 Fax

kitchenkompact.com



Kitchen Kompact is certified under the Kitchen Cabinet Manufacturers Association's Environmental Stewardship Program*.

* This certification has been recognized by the National Association of Home Builders' (NAHB) with the Green Building Award for Advocate of the Year for its environmental and sustainability achievements.

Wall Cabinets

Kitchen Kompact, Inc.
911 E. 11th St. (47130)
P.O. Box 868
Jeffersonville, IN 47131-0868
TEL: 812/282-6681
FAX: 812/282-7880
www.kitchenkompact.com



Frames: All frames are built of solid 3/4" hardwoods. Each rail is kiln-dried, joined by mortise and tenon, then glued for added strength.

End Panels: End panels are wood veneered, 1/2" thick engineered wood core plywood, fastened to front frame with tongue-in-groove construction.

Backs: 1/8" hardboard recessed in sides.

Tops & Bottoms: 3/16" hardboard dadoed into sides, interlocked into hanging rails of all wall units, and secured with an adhesive for added strength.

Hanging Rails: Solid wood, 3/4" x 2-5/8", located at top and bottom.

Shelves: All wall cabinets feature adjustable shelves. A selection of six different heights is built into each 30" high and taller wall cabinet. On 2-door wall units, the center 3" stile is used for center support of adjustable shelves. It is recommended that a 1/4" hole be drilled in the back for additional center support. The extra shelf clip is provided. Shelves are 1/2" engineered wood, with rounded front edge and printed wood grain.

Hardware: Chadwood, Glenwood, Warmwood and DWhite feature concealed self-closing hinges — no door pulls included.

Finish: A 4-step process is applied to the exterior finish of Glenwood, Warmwood, and Chadwood: Stain, Sealer, Sanding, and Catalyzed Top Coat. This finish is resistant to household chemicals such as water, beverages, mild acids — even nail polish. A 3-step process is applied to the exterior finish of DWhite: Primer (2 coats), Sanding, and Enamel.

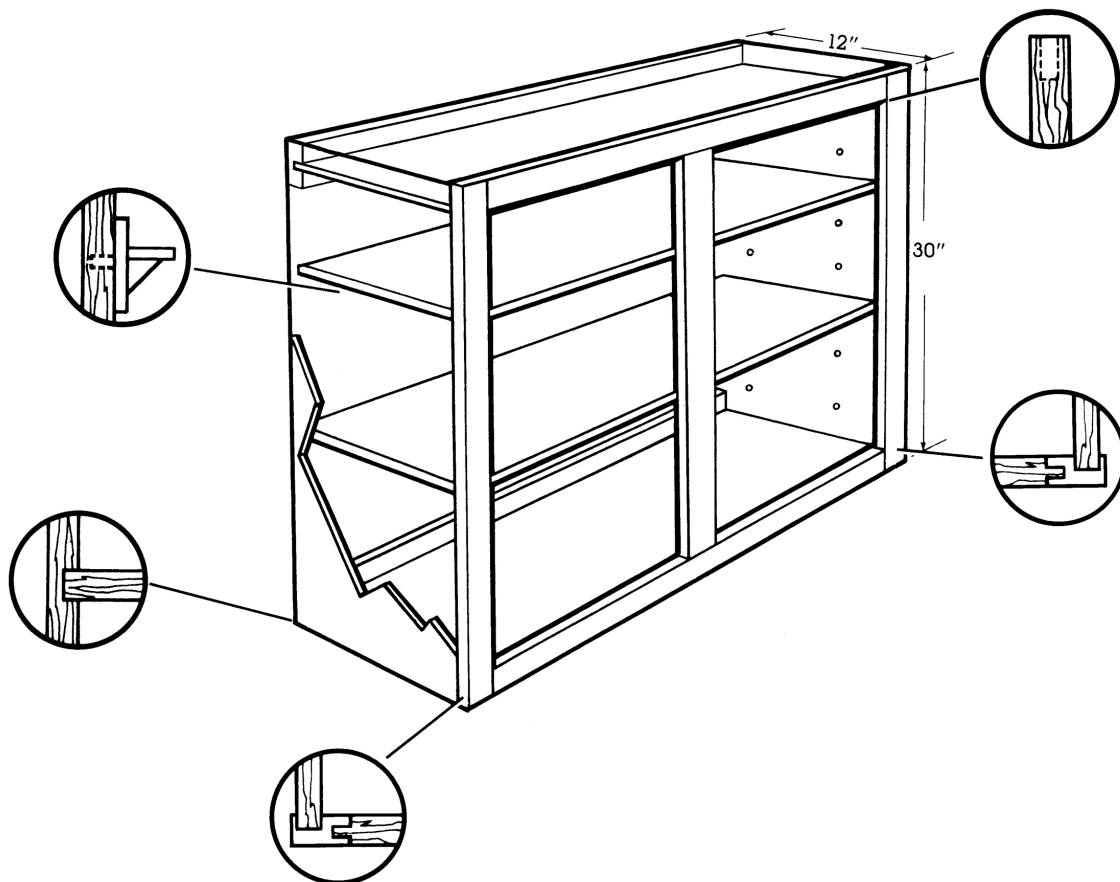

Base Cabinets

Kitchen Kompact, Inc.
911 E. 11th St. (47130)
P.O. Box 868
Jeffersonville, IN 47131-0868
TEL: 812/282-6681
FAX: 812/282-7880
www.kitchenkompact.com



Frames: All frames are built of solid 3/4" hardwoods. Each rail is kiln-dried, joined by mortise and tenon, then glued for added strength.

End Panels: End panels are wood veneered, 1/2" thick engineered wood core plywood, fastened to front frame with tongue-in-groove construction.

Backs: 1/8" hardboard, recessed in sides.

Bottoms: 3/16" hardboard dadoed into sides and power nailed into supporting strips.

Hanging Rails: Solid wood, 3/4" x 1-1/2", located at top.

Corners: Plastic corner braces power nailed.

Toe Kick: 3/4" pine.

Shelf: 1/2" engineered wood 11" deep dadoed into sides, with rounded front edge and printed wood grain.

Hardware: Chadwood, Glenwood, Warmwood, and DWhite feature concealed self-closing hinges — no door pulls included.

Finish: A 4-step process is applied to the exterior finish of Glenwood, Warmwood, and Chadwood: Stain, Sealer, Sanding, and Catalyzed Top Coat. This finish is resistant to household chemicals such as water, beverages, mild acids — even nail polish. A 3-step process is applied to the exterior finish of DWhite: Primer (2 coats), Sanding, and Enamel.

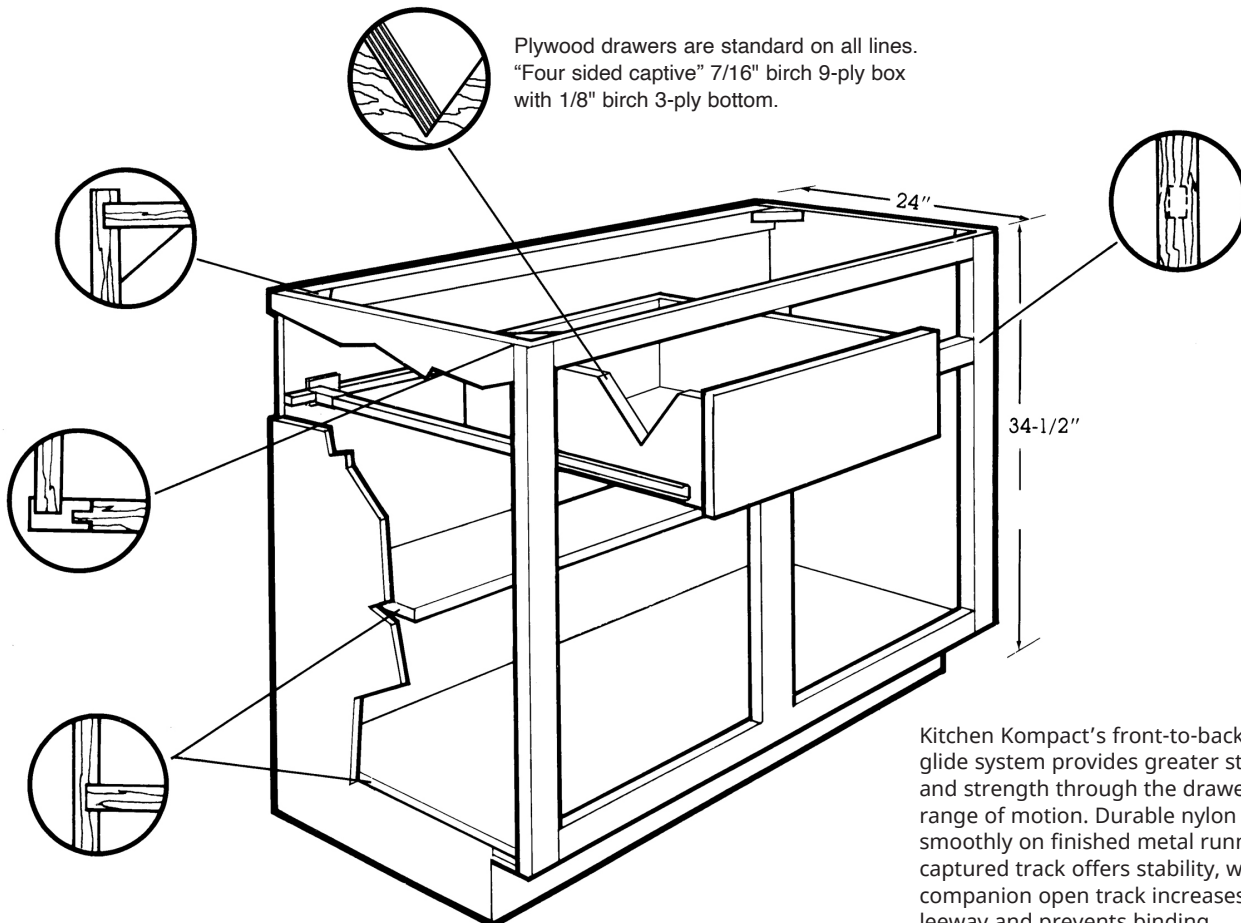

Lazy Susan

Kitchen Kompact, Inc.
911 E. 11th St. (47130)
P.O. Box 868
Jeffersonville, IN 47131-0868
TEL: 812/282-6681
FAX: 812/282-7880
www.kitchenkompact.com



Frames: All frames are built of solid 3/4" hardwoods. Each rail is kiln-dried, joined by mortise and tenon, then glued for added strength.

End Panels: Not required unless cabinet is used at the end of a run.

Toe Kick: 3/4" pine.

Shelf: High impact polystyrene shelves have internal struts for maximum strength.

Hardware: Engineered with an adjustable mechanism (detail A) for aligning the vertical and rotational position of cabinet doors within the cabinet frame. The nylon gear and cam mechanism requires no lubrication.

Finish: A 4-step process is applied to the exterior finish of Glenwood, Warmwood, and Chadwood: Stain, Sealer, Sanding, and Catalyzed Top Coat. This finish is resistant to household chemicals such as water, beverages, mild acids - even nail polish. A 3-step process is applied to the exterior finish of DWhite: Primer (2 coats), Sanding, and Enamel.

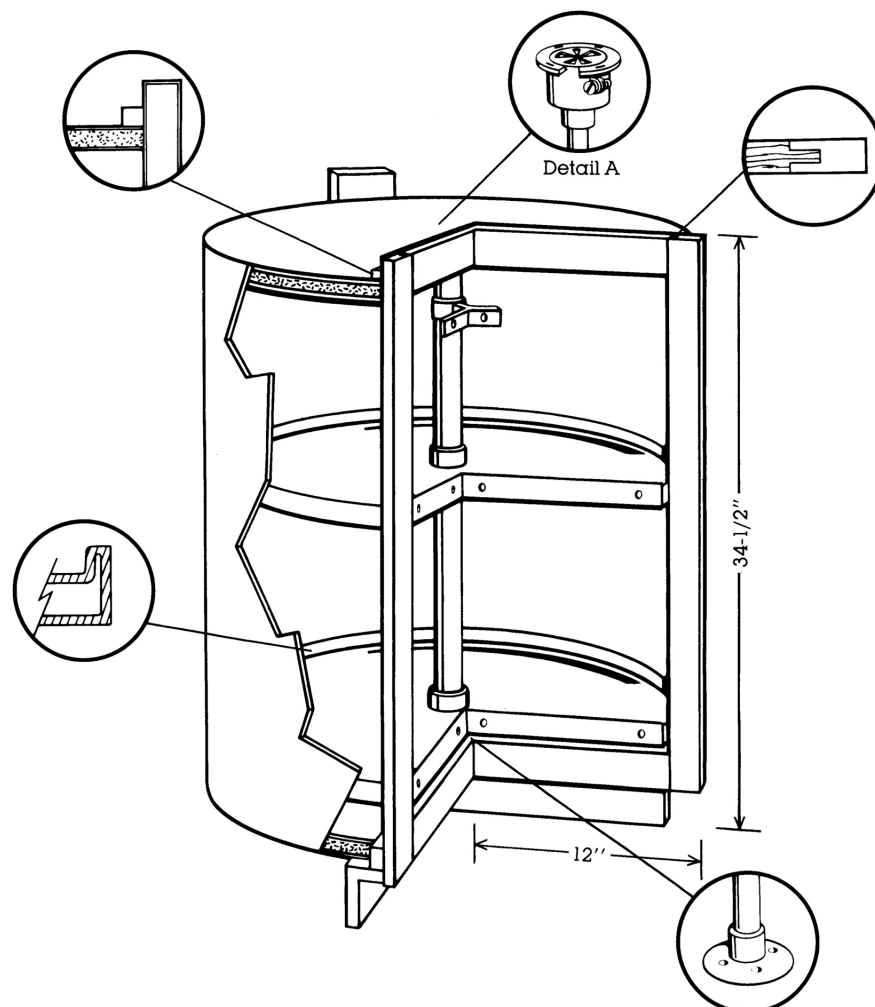

INSTALLATION AND CARE GUIDELINES

- Cabinets must be attached to wall studs with screws, not nails, for full support.
- Check each cabinet as it is installed to ensure that it is level and plumb. Sand or shim where needed. Remove baseboard and chair rails from behind cabinets for a flush fit.
- To protect cabinets, do not remove them from cartons until ready to be installed. Never use an installed cabinet as a workbench.
- To protect the finish, wipe up spills promptly. Clean occasionally with a soft, damp cloth and dry immediately. Use no abrasives. Wax periodically with a liquid wax.
- Avoid such unnecessary moisture as towels draped over doors and steaming coffee machines under cabinets. Place appliances carefully so as to avoid unnecessary extremes of temperature.
- Do not swing on or slam doors or drawers. Do not overload shelves. Use bumper pads provided to absorb the impact of closing and protect against splitting of doors.

Beginning Installation

- Always install with 2-1/2" or longer wood screws. Never use nails.
- Always begin with a base corner cabinet and alternate cabinets to each side.



Start base cabinets in corner

- Use "C" clamps to obtain proper alignment when connecting cabinets. Secure with T-nuts and 1/2" bolts through end panels and adjoining cabinets, or drill and screw through the stiles of the face frame.



Use "C" clamps to align

- To prevent backrail from bowing, install a block between cabinet back and wall.
- After base units are installed, cover toe-kick with optional material. Attach counter tops and cover with cartons for protection.
- Begin wall cabinets with a corner unit. From inside, screw through hanging strips at back of cabinets 3/4" above bottom shelf and 3/4" below top shelf. Adjust loosely.

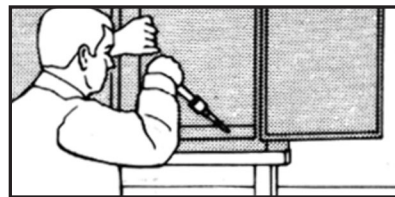

Start wall cabinets in corner

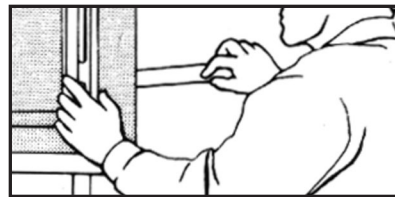

Use shims as needed

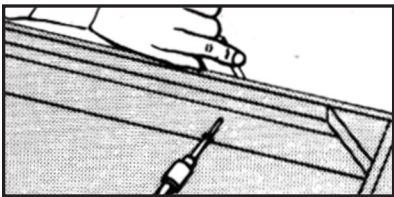

Attach to wall studs

- After aligning, tighten all screws.
- After installing adjustable shelves in desired position in double door cabinets, mark a line at bottom center of each shelf on the inside back wall of the cabinet. Remove shelves and drill 1/4" hole 3/16" below each line on the inside back wall of the cabinet. Install shelf support in back and front stiles and replace shelf.

Notes





NATIONWIDE MANUFACTURER OF KITCHEN AND BATH CABINETS
SINCE 1937

Warranty

Kitchen Kompact, Inc. warrants to the purchaser of Kitchen Kompact cabinets that any part, which proves to be defective, within one year from the date of installation, will be replaced to the distributor without charge.

Wood Characteristics & Painted Finishes On all wood products, expansion, contraction and warping are typical due to changes in climate conditions. Painted finishes may develop slight separation lines, finish breaks and seam lines. These changes will be most noticeable at stiles, rails and panel joints. Painted and stained finishes are also susceptible to changes in color due to exposure to natural light, extreme heat, smoke, abrasive cleansers, etc. The changes may become more noticeable over time and through seasonal changes. These changes are normal and are not considered quality defects. This warranty does not extend to normal wear and tear, or to damage by circumstance beyond the manufacturer's control and does not include any replacement labor. Any alterations to the structure of the cabinets, or its parts will void this warranty.

If any such part is claimed defective, claim should be referred to the distributor from whom the Kitchen Kompact cabinets were purchased.

Kitchen Kompact, Inc.
P.O. Box 868
Jeffersonville, IN 47131-0869



800.652.1234

palmerdonavin.com

